

# European system solution for retaining walls

Modular  
block system with  
**23** concrete blocks

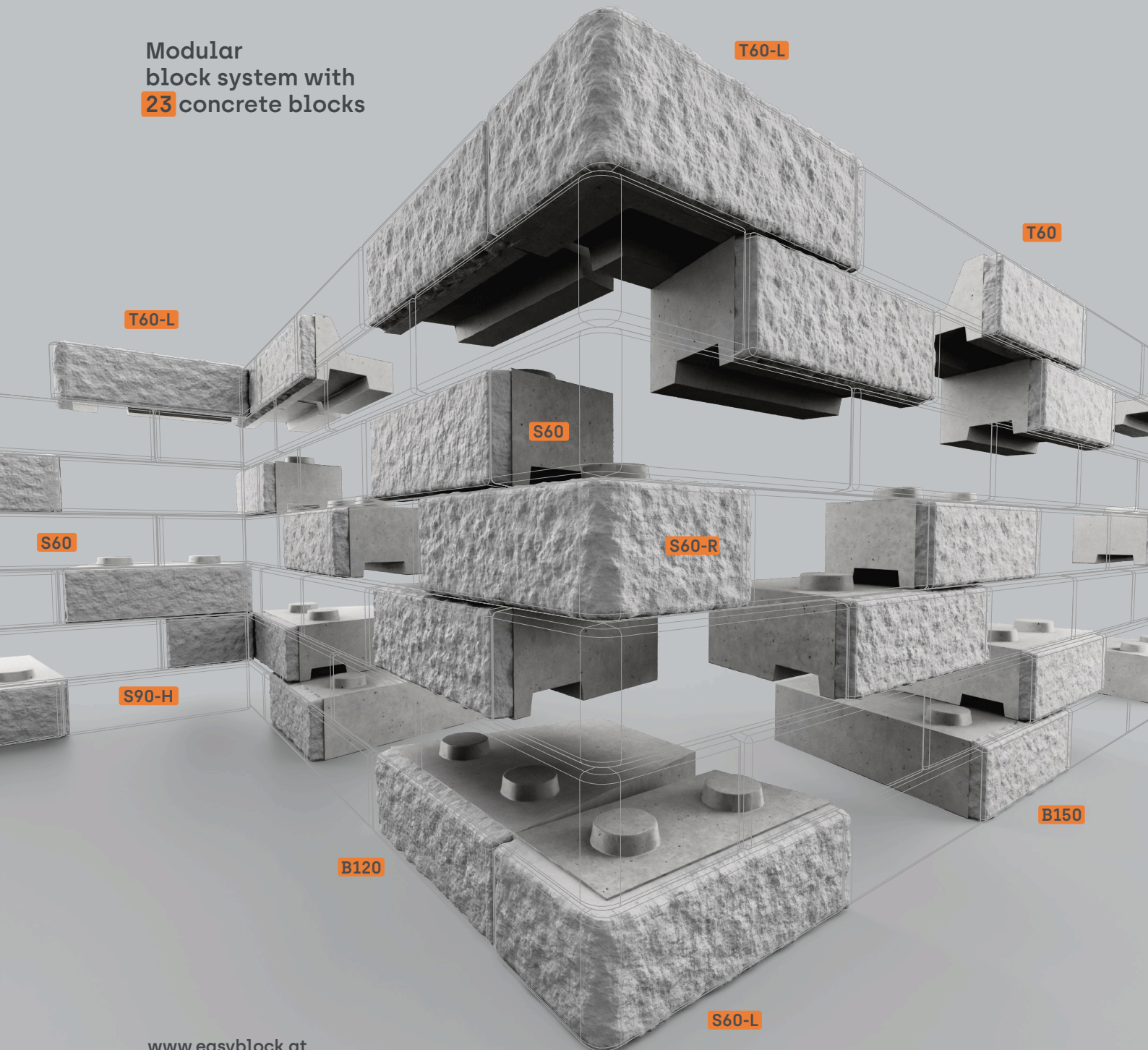





## The block system

With 23 optimized block types, the Easyblock system offers maximum flexibility in the wall design and installation of retaining walls. The precise interlocking system enables a perfect installation and high structural safety. The system has a proven track record in many European countries.

- +** Wide range of applications
- +** Fast and flexible construction
- +** Natural stone aesthetics
- +** Tested and documented structural stability
- +** Optimized cost efficiency
- +** Direct delivery to the construction site

## Wide range of applications

The block system is used in gardening and landscaping, slope and embankment stabilization, lakeshore and riverbank stabilization, water management applications, and infrastructure projects of all kinds.



## **+** Natural stone aesthetics

A range of surface finishes allows seamless integration into any environment, enhanced by the natural look of the retaining wall. Precisely formed corners without visible chamfers deliver a clean, refined, and premium appearance. Whether you prefer a Granite or Rock stone finish, you can choose the style that best suits your vision. All Easyblock units are maintenance-free and designed to last for generations.



Stone Surface

Granite stone texture



Stone Surface

Rock texture

## + Flexible design possibilities

Starting from a height of just 40 cm, Easyblock offers virtually limitless possibilities. Its flexible system design allows even challenging terrains and complex requirements to be realised with ease, adapting seamlessly to a wide range of site conditions.

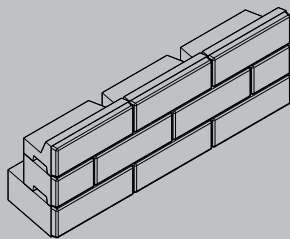

**1 Straight wall**  
The simplest wall shape

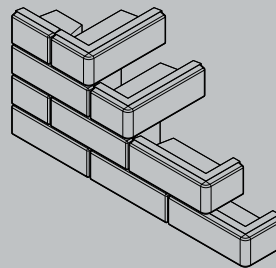

**2 Variable stepping options**  
Design with corner blocks

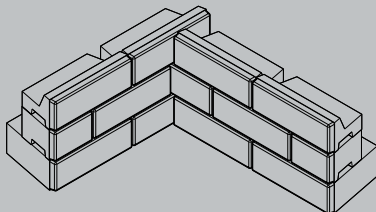

**3 90° Inside Corner**  
Same blocks as for the straight wall

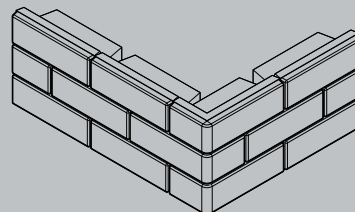

**4 90° Outside Corner**  
Additional corner blocks

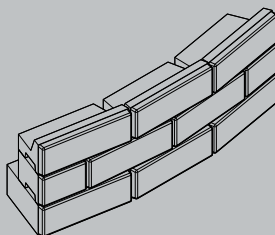

**5 Convex curve**  
Maximum radius up to 20°

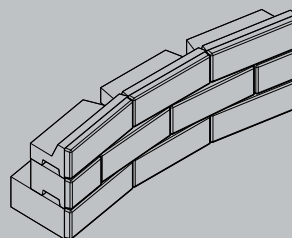

**6 Concave curve**  
Maximum radius up to 20°

## + Fast and cost-efficient construction

When ideas need to become reality quickly, Easyblock stands out with its simple and highly efficient planning and construction process. Using advanced planning software, multiple design options can be explored in minutes, enabling early evaluation and optimal project preparation. From excavation to the finished retaining wall, projects are often completed within just a few days — typically without the need for a concrete foundation, depending on wall height and design. A precise installation plan ensures a clear, step-by-step construction process, carried out by a two-person team using a mini excavator. This allows for fast, efficient, and reliable progress on site.

Example of construction time and costs: Retaining wall 25 m long + 2.0 m high = 50 m<sup>2</sup>

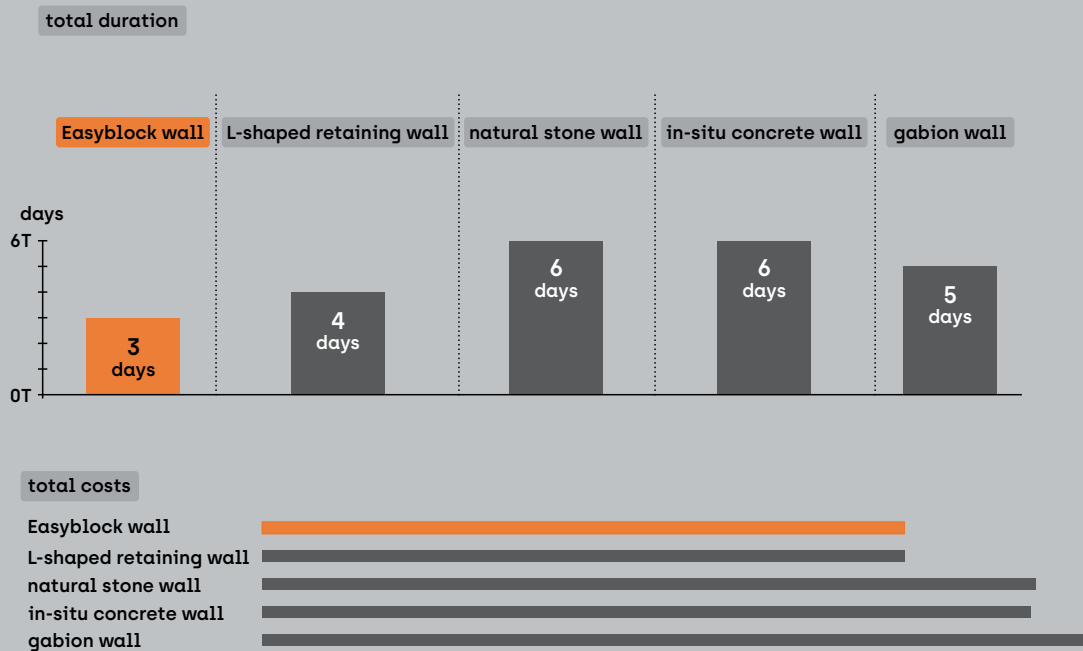

## + Dry construction method

No mortar. No waiting times. Just straightforward simplicity built on precise planning. Easyblock is installed block by block directly on a frost protection layer—only exceptionally high walls require a concrete foundation. Every step is efficient, and each block fits perfectly thanks to the knob-and-groove system. With typically up to 50 blocks installed per day, Easyblock saves valuable time, reduces effort, and delivers real cost efficiency.

**+ Tested and documented structural stability**

Structural stability is ensured for both gravity and geogrid-reinforced wall systems. For quick and efficient dimensioning, design chart tables are available covering typical wall parameters such as wall height, setback, soil conditions, and load cases. The Easyblock system has been tested for structurally verified in accordance with Eurocode 7.

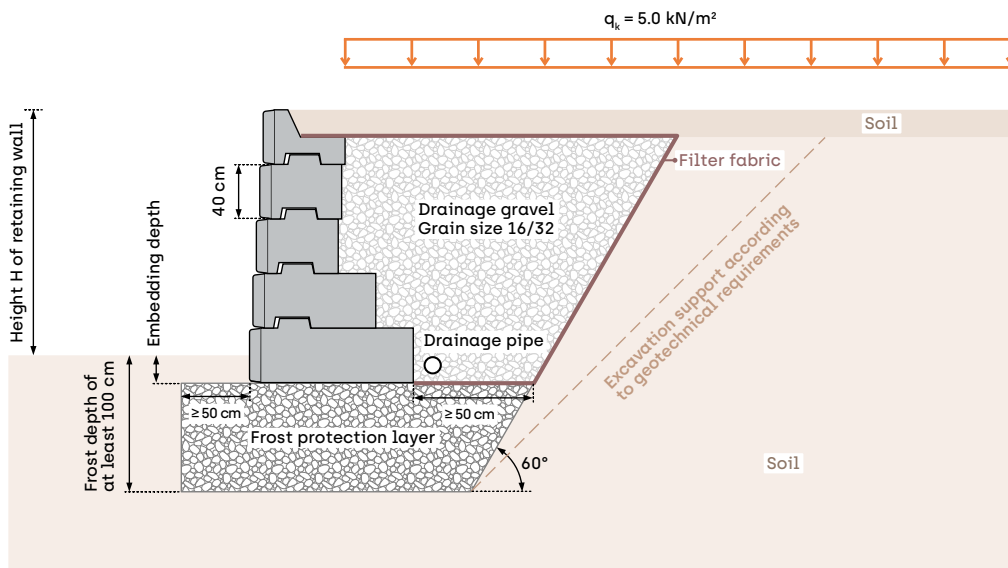

**Configuration design - Soil type Silt**

WT.Incl TT.Flat ST.Silt

Gravity wall, inclined / Flat terrain  $\alpha = 3,6^\circ$ ,  $\beta = 0^\circ$ ,  $q_k = 5.0 \text{ kN/m}^2$

Height in cm	Number of block rows									
	1	2	3	4	5	6	6F	7F	8F	
400										
360										
320										60
280								60	60	60
240						60	60	60	60	90
200					60	60	60	60	90	90
160			60	60	60	90	90	90	90	120
120		60	60	60	90	120	150	90	120	150
80	60	60	60	90	120	150	220	220	260	300
40	60	60	60	90	120	150	220	220	260	300
F							F	F	F	
ED	20	20	20	20	20	20	20	20	20	20
H	20	60	100	140	180	220	220	260	300	

## + Planning and cost certainty

With verified standards and dedicated software support, retaining walls can be designed efficiently. Different variants can be quickly compared, and feasibility can be assessed early in the project. Support from Easyblock engineers provides additional guidance throughout the entire process.

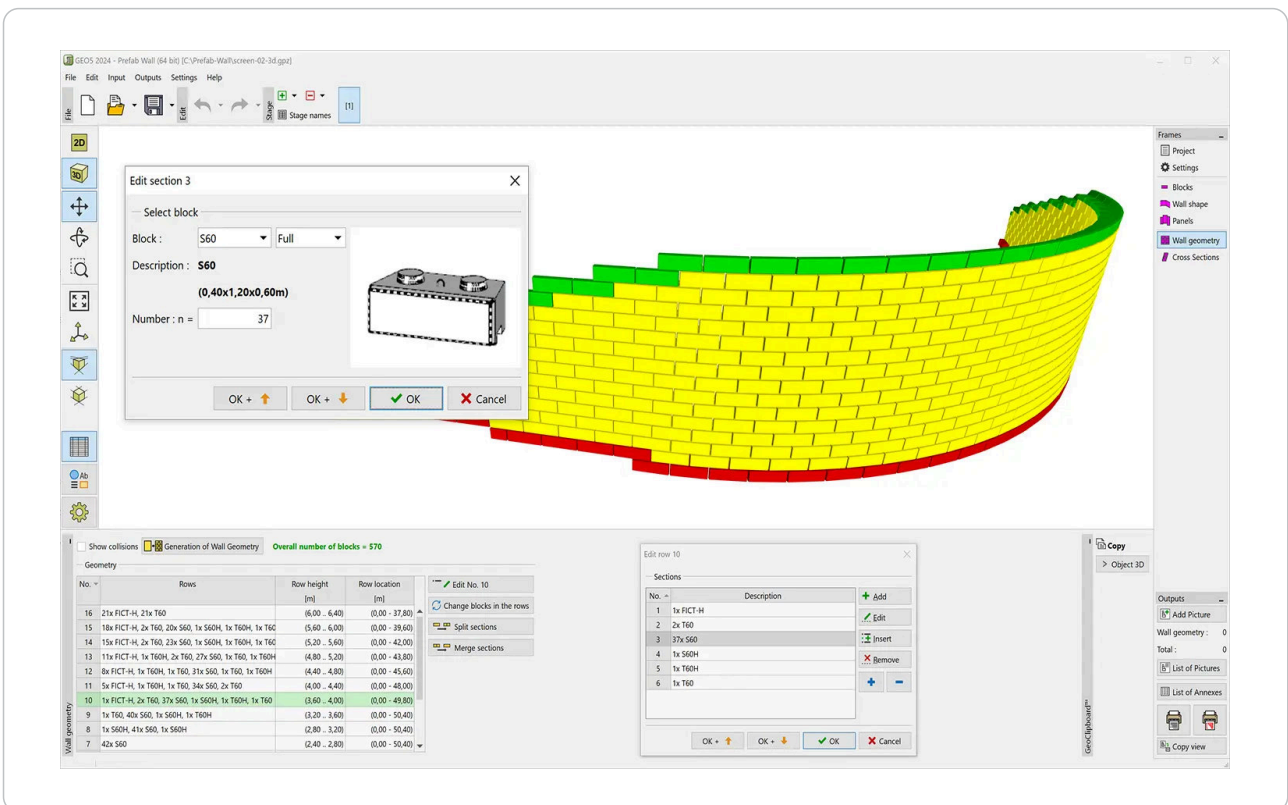
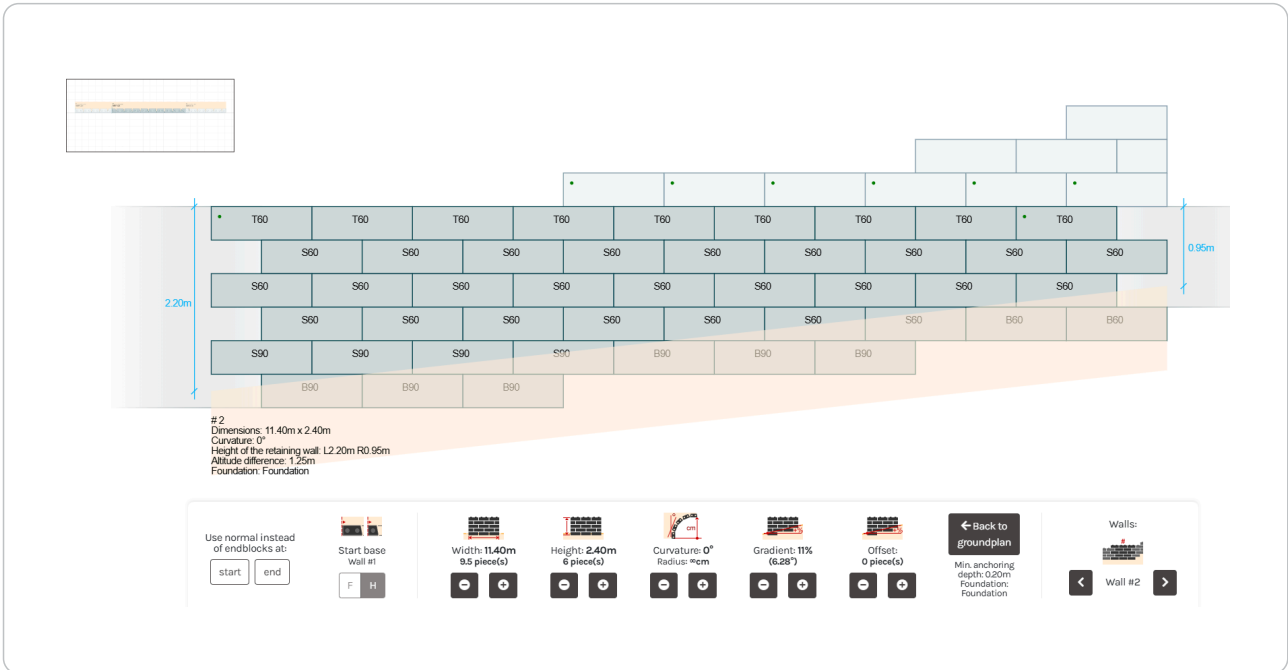









Blocksystem  
Designation scheme

# S60-LH

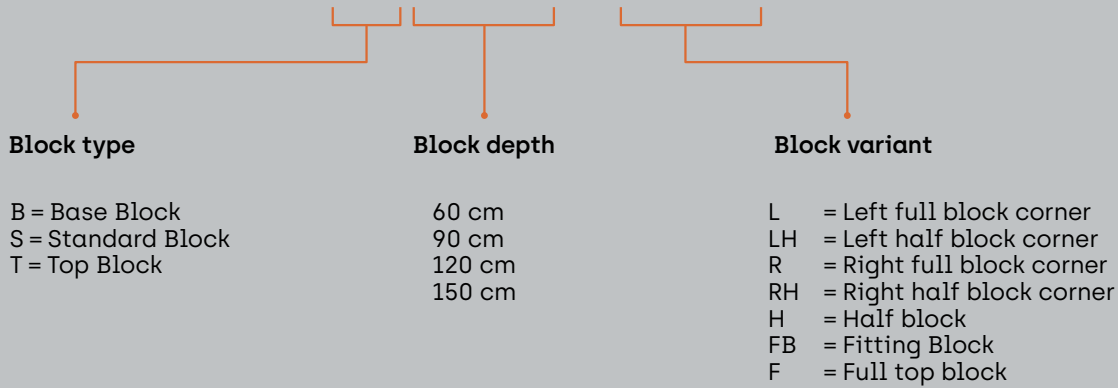

## Block architecture

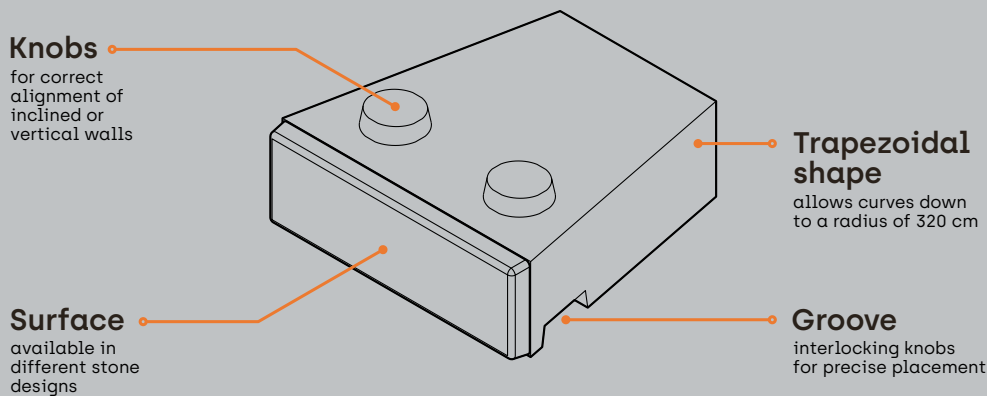

## Technical characteristics

Color	Concrete gray
Maximum unit weight	1.240 kg [B150 Base Block]
Corner angle	Up to 90° possible
Curvature	Up to 20° possible [= approx. 350 cm radius]
Wall height	4,0 m [Gravity wall ] 5,6 m [Geogrid wall]

Higher wall heights can be realized with project-specific structural analysis.

## Test results and evidence

Structural analysis	EN 1997-1 [Eurocode 7] EN 1992-1-1 [Eurocode 2]
Application	EN 15258
Evidence	Pull out test Geogrid wall Pull out test lifting means

Easyblock block system – 23 blocks in 3 groups

Each block is 40 cm high.

Base Blocks

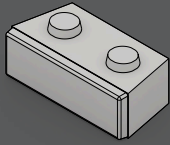

**B60**

639 kg  
120 x 60 cm

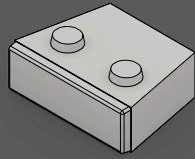

**B90**

904 kg  
120 x 90 cm

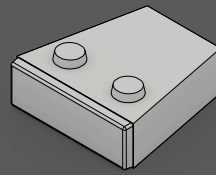

**B120**

1.077 kg  
120 x 120 cm

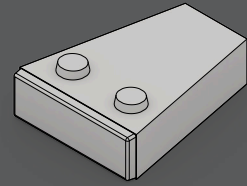

**B150**

1.240 kg  
120 x 150 cm

Standard Blocks

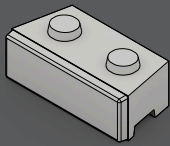

**S60**

585 kg  
120 x 60 cm

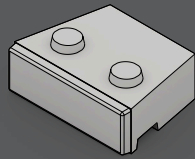

**S90**

850 kg  
120 x 90 cm

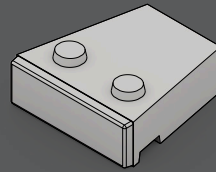

**S120**

1.005 kg  
120 x 120 cm

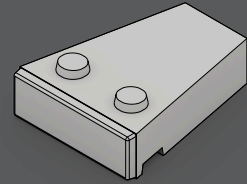

**S150**

1.190 kg  
120 x 150 cm

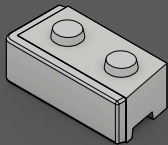

**S60-L**

613 kg  
120 x 60 cm

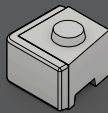

**S60-LH**

296 kg  
60 x 60 cm

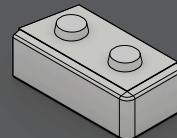

**S60-R**

613 kg  
120 x 60 cm

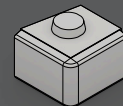

**S60-RH**

296 kg  
60 x 60 cm

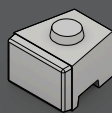

**S60-H**

267 kg  
60 x 60 cm

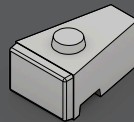

**S90-H**

362 kg  
60 x 90 cm

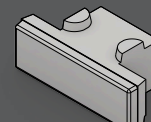

**S60-FB**

389 kg  
120 x 60 cm

Top Blocks

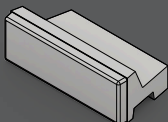

**T60**

381 kg  
120 x 60 cm

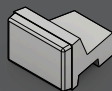

**T60-H**

178 kg  
60 x 60 cm

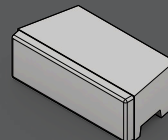

**T60-F**

530 kg  
120 x 60 cm

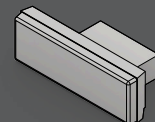

**T60-FB**

281 kg  
120 x 60 cm

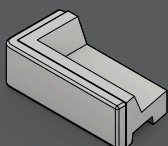

**T60-L**

438 kg  
120 x 60 cm

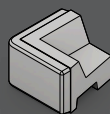

**T60-LH**

234 kg  
60 x 60 cm

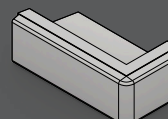

**T60-R**

438 kg  
120 x 60 cm



**T60-RH**

234 kg  
60 x 60 cm



## easy block GmbH

9300 St. Veit/Glan  
Altglandorf 22  
Austria

+43(0)4212/5454  
info@easyblock.at  
www.easyblock.at

VAT No.: ATU77709268  
Company registration number: 571466 t

T60-L

B150